



PTC Thermistor

Overcurrent protection

Series/Type: C0985-A0120-A051
Ordering code: B59985C0120A051
Date: 2015-04-30
Version: a

© EPCOS AG 2015. Reproduction, publication and dissemination of this publication, enclosures hereto and the information contained therein without EPCOS' prior express consent is prohibited.

EPCOS AG is a TDK Group Company.

Applications

- Overcurrent protection
- Short circuit protection

Features

- Lead free terminals
- Marking: Type, Manufacturer's logo, reference temperature in °C and date code YYWW
- Short response time
- UL approval to UL 1434 with $V_{max} = 15V$ and $V_R = 12V$ (file number E69802)
- RoHS-compatible

Delivery mode

- Cardboard tape reeled

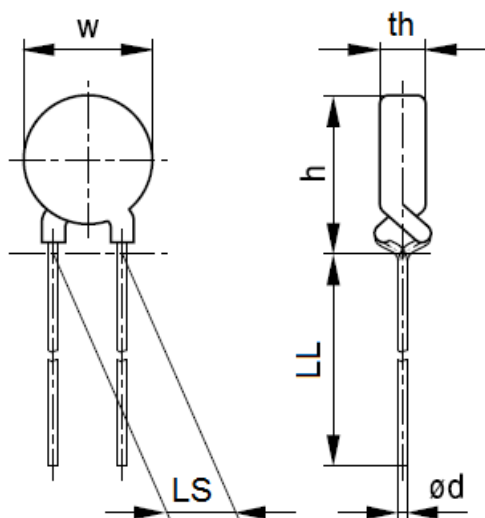
Dimensions and drawing

W_{\max}	6.5	mm
th_{\max}	3.5	mm
h_{\max}	10.0	mm
d	0.6 ± 0.05	mm
LS	$5.0 +0.6/-0.1$	mm
LL	acc. to tape	

General Technical Data

Max. operating voltage ($T_a = 60^\circ\text{C}$)	V_{\max}	30	V_{DC} or V_{AC}
Rated voltage	V_R	12,24	V_{DC} or V_{AC}
Rated resistance at T_{amb}	R_{25}	4.6	Ω
Rated resistance tolerance at T_{amb}	ΔR_{25}	± 25	%
Min. resistance	R_{\min}	2.7	Ω
Rated current	I_R	250	mA
Switching current	I_S	500	mA
Maximal permissible switching current at V_{\max}	$I_{S\max}$	1.0	A
Residual current at V_{\max} (typ.) for information only	I_{res}	45	mA
Reference temperature (typ.) for information only	T_{ref}	120	$^\circ\text{C}$
Operating temperature range ($V = 0$)	$T_{\text{op}}(0)$	-40/+125	$^\circ\text{C}$
Operating temperature range ($V = V_{\max}$)	$T_{\text{op}}(V_{\max})$	-40/+85	$^\circ\text{C}$

Specification for $T_{\text{amb}} = 25^\circ\text{C}$

Reliability data

Test	Standard	Test conditions	$ \Delta R_{25}/R_{25} $
Electrical endurance, cycling	IEC 60738-1	Room temperature, I_{Smax} ; V_{max} Number of cycles: 100	<25%
Electrical endurance, constant	IEC 60738-1	Storage at $V_{max}/T_{op,max}$ (V_{max}) Test duration: 1000h	<25%
Damp heat	IEC 60738-1	Temperature of air: 40°C Relative humidity of air: 93% Duration: 56 days Test according to IEC 60068-2-78	<10%
Rapid change of temperature	IEC 60738-1	$T_1 = T_{op,min}$ (0 V), $T_2 = T_{op,max}$ (0 V) Number of cycles: 5 Test duration: 30min Test according to IEC 60068-2-14, Test Na	<10%
Vibration	IEC 60738-1	Frequency range: 10 to 55 Hz Displacement amplitude: 0.75mm Test duration: 3x2 h Test according to IEC 60028-2-6, Test Fc	<5%
Shock	IEC 60738-1	Acceleration: 390m/s ² Pulse duration : 6ms 6 x 4000 pulse	< 5%
Climatic sequence	IEC 60738-1	Dry heat: $T = T_{op,max}$ (0 V) Test duration: 16 h Damp heat first cycle Cold $T = T_{op,min}$ (0 V) Test duration: 2h Damp heat 5 cycle Tests performed according to IEC 60068-2-30	<10%

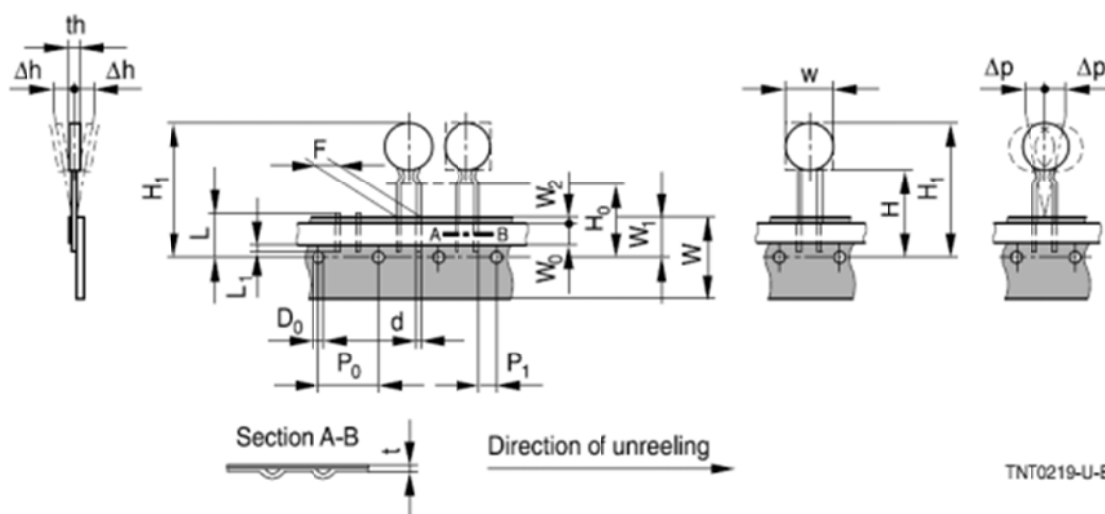
Taping

Dimensions and tolerances (taping in accordance with IEC 60286-2):

Designation	Symbol	Nominal size [mm]	Tolerance [mm]	Remarks
Pitch of holes	P_0	12.7	± 0.3	± 1 mm/20 sprocket holes
Spacing hole center	P_1	3.85	± 0.7	
Spacing of the lead	F	5.0	+0.6/-0.1	
Diameter of the lead	d	0.6	± 0.05	
Slope of component	Δh	0	± 2.0	Measured at top of component body
Slope of component	Δp	0	± 1.3	
Carrier type width	W	18.0	+1.0/-0.5	
Hot adhesive tape width	W_0	5.5	min.	peel-off force ≥ 5 N
Position of holes	W_1	9.0	+0.75/-0.5	
Position of adhesive tape	W_2	3.0	max.	
Spacing hole center / bottom edge of component	H	18	+2/-0	non-kinked lead version only
Spacing hole center / kink level	H_0	16.0	± 0.5	kinked lead version only
Spacing hole center / upper edge of component	H_1	32.2	max.	
Hole diameter	D_0	4.0	± 0.2	
Tape thickness	t	0.9	max.	without wires
Length of remaining wire after removal of component	L	11.0	max.	
Length of wire below adhesive tap	L_1	4.0	Max.	

Cautions and warnings

General

- EPCOS thermistors are designed for specific applications and should not be used purposes not identified in our specifications, application notes and data books unless otherwise agreed with EPCOS during the design-in-phase.
- Ensure suitability of thermistor through reliability testing during the design-in phase. The thermistors should be evaluated taking into consideration worst-case conditions.

Storage

- Store thermistors only in original packaging. Do not open the package before storage.
- Storage conditions in original packaging: storage temperature -25°C... +45°C, relative humidity $\leq 75\%$ annual mean, maximum 95%, dew precipitation is inadmissible.
- Avoid contamination of thermistors surface during storage, handling and processing.
- Avoid storage of thermistor in harmful environment with effect on function on long-term operation (examples given under operation precautions).
- Use thermistor within the following period after delivery:
 - Through-hole devices (housed and leaded PTCs): 24 months
 - Motor protection sensors, glass-encapsulated sensors and probe assemblies: 24 months
 - Telecom pair and quattro protectors (TPP, TQP): 24 months
 - Leadless PTC thermistors for pressure contacting: 12 months
 - Leadless PTC thermistors for soldering: 6 months
 - SMDs in EIA sizes 3225 and 4032, and for PTCs with metal tags: 24 months
 - SMDs in EIA sizes 0402, 0603, 0805 and 1210: 12 months

Handling

- PTCs must not be dropped. Chip-offs must not be caused during handling of PTCs.
- Components must not be touched with bare hands. Gloves are recommended.
- Avoid contamination of thermistor surface during handling.

Soldering

- Use rosin-type flux or non-activated flux.
- Insufficient preheating may cause ceramic cracks.
- Rapid cooling by dipping in solvent is not recommended.
- Complete removal of flux is recommended.
- Standard PTC heaters are not suitable for soldering.

Mounting

- Electrode must not be scratched before/during/after in the mounting process.
- Contacts and housing used for assembly with thermistor have to be clean before mounting. Especially grease or oil must be removed.
- When PTC thermistors are encapsulated with sealing material, the precautions given in chapter "Mounting instructions", "Sealing and potting" must be observed.
- When the thermistor is mounted, there must not be any foreign body between the electrode of the thermistor and the clamping contact.
- The minimum force of the clamping contacts pressing against the PTC must be 10 N.

- During operation, the thermistor's surface temperature can be very high. Ensure that adjacent components are placed at a sufficient distance from the thermistor to allow for proper cooling at the thermistors.
- Ensure that adjacent materials are designed for operation at temperature comparable to the surface temperature of thermistor. Be sure that surrounding parts and materials can withstand this temperature.
- Avoid contamination of thermistor surface during processing.

Operation

- Use thermistors only within the specified temperature operating range.
- Use thermistors only within the specified voltage and current ranges.
- Environmental conditions must not harm the thermistors. Use thermistors only in normal atmospheric conditions. Avoid use in deoxidizing gases (chlorine gas, hydrogen sulfide gas, ammonia gas, sulfuric acid gas etc), corrosive agents, humid or salty conditions. Contact with any liquids and solvents should be prevented.
- Be sure to provide an appropriate fail-safe function to prevent secondary product damage caused by abnormal function (e.g. use VDR for limitation of over voltage condition).

Display of ordering codes for EPCOS products

The ordering code for one and the same EPCOS product can be represented differently in data sheets, data books, other publications, on the EPCOS website, or in order-related documents such as shipping notes, order confirmations and product labels. **The varying representations of the ordering codes are due to different processes employed and do not affect the specifications of the respective products.** Detailed information can be found on the Internet under www.epcos.com/orderingcodes

Important notes

The following applies to all products named in this publication:

1. Some parts of this publication contain **statements about the suitability of our products for certain areas of application**. These statements are based on our knowledge of typical requirements that are often placed on our products in the areas of application concerned. We nevertheless expressly point out **that such statements cannot be regarded as binding statements about the suitability of our products for a particular customer application**. As a rule, EPCOS is either unfamiliar with individual customer applications or less familiar with them than the customers themselves. For these reasons, it is always ultimately incumbent on the customer to check and decide whether an EPCOS product with the properties described in the product specification is suitable for use in a particular customer application.
2. We also point out that **in individual cases, a malfunction of electronic components or failure before the end of their usual service life cannot be completely ruled out in the current state of the art, even if they are operated as specified**. In customer applications requiring a very high level of operational safety and especially in customer applications in which the malfunction or failure of an electronic component could endanger human life or health (e.g. in accident prevention or life-saving systems), it must therefore be ensured by means of suitable design of the customer application or other action taken by the customer (e.g. installation of protective circuitry or redundancy) that no injury or damage is sustained by third parties in the event of malfunction or failure of an electronic component.
3. **The warnings, cautions and product-specific notes must be observed.**
4. In order to satisfy certain technical requirements, **some of the products described in this publication may contain substances subject to restrictions in certain jurisdictions (e.g. because they are classed as hazardous)**. Useful information on this will be found in our Material Data Sheets on the Internet (www.epcos.com/material). Should you have any more detailed questions, please contact our sales offices.
5. We constantly strive to improve our products. Consequently, **the products described in this publication may change from time to time**. The same is true of the corresponding product specifications. Please check therefore to what extent product descriptions and specifications contained in this publication are still applicable before or when you place an order. We also **reserve the right to discontinue production and delivery of products**. Consequently, we cannot guarantee that all products named in this publication will always be available. The aforementioned does not apply in the case of individual agreements deviating from the foregoing for customer-specific products.
6. Unless otherwise agreed in individual contracts, **all orders are subject to the current version of the "General Terms of Delivery for Products and Services in the Electrical Industry" published by the German Electrical and Electronics Industry Association (ZVEI)**.
7. The trade names EPCOS, Alu-X, CeraDiode, CeraLink, CeraPad, CeraPlas, CSMP, CSSP, CTVS, DeltaCap, DigiSiMic, DSSP, ExoCore, FilterCap, FormFit, LeaXield, MiniBlue, MiniCell, MKD, MKK, MotorCap, PCC, PhaseCap, PhaseCube, PhaseMod, PhiCap, PQSine, SIFERRIT, SIFI, SIKOREL, SilverCap, SIMDAD, SiMic, SIMID, SineFormer, SIOV, SIP5D, SIP5K, TFAP, ThermoFuse, WindCap are **trademarks registered or pending** in Europe and in other countries. Further information will be found on the Internet at www.epcos.com/trademarks.